

Index

1. GENERAL INFORMATION	3
1.1 - GENERAL SAFETY RECOMMENDATIONS	3
1.2 - FIELDS OF APPLICATION	4
1.3 - OVERALL DIMENSIONS	4
1.4 - TECHNICAL DATA	5
2. MOVING THE CABINET	5
3. POWER SUPPLY	5
4. CONTROLS AND FUNCTIONS	6
5. WHEEL BALANCING MACHINE INSTRUCTIONS	7
5.1 - PREPARING FOR BALANCING	7
5.2 - POSITIONING THE PICK-UPS	7
5.3 - POSITIONING THE BALANCING MACHINE	7
5.4 - BALANCING NON-DRIVE WHEELS	8
5.5 - IMPORTANT NOTES	8
5.6 - BALANCING DRIVE WHEELS USING THE BALANCING MACHINE MOTOR	10
5.7 - BALANCING DRIVE WHEELS USING THE VEHICLE MOTOR	10
6. ERRORS	11
7. ORDINARY MAINTENANCE	11
8 - RECOMMENDED SPARE PARTS LIST	11

1 - General information

The balancing machine is an instrument with a new design that guarantees exceptional performance in on-vehicle wheel balancing. Its microprocessor-based electronics and its new measuring system enable it to provide perfect balancing for wheels in two or at the most three spins, even in the most difficult cases where it used to be necessary to use the trial and error method. In fact, unlike traditional stroboscopic balancing machines, this machine automatically corrects any inaccuracy in the position reading due to various causes (the way the transducer is positioned, the type of suspension etc.) and eliminates any complex operations for calibrating the unbalance value by trial and error.

Another unique advantage is the fact that the machine is simple to use, eliminating the need for especially expert operators. During the wheel spin, the balancing machine also provides a reading of the wheel's rotation speed on the digital display on the right, which is extremely useful as a reference speed, according to the type of vehicle in question.

Model with motor cooling fan is particularly used for continuous operation on trucks.

1.1 - General safety recommendations

- Read the user's instruction manual carefully before using the balancing machine.
- Keep the manual for future reference.
- Do not remove or change any parts of the machine: this would stop it functioning properly. Consult the after-sales service for any repairs.
- Do not use strong jets of compressed air to clean the machine.
- Use a spirit cleaner to clean the panels or shelves in plastic (**DO NOT USE LIQUIDS CONTAINING SOLVENTS**).
- Before starting the balancing cycle up, make sure that the transducers are in the right position under the vehicle.
- The balancing machine operator must not wear clothing with trailing parts. Make sure that no unauthorised people approach the balancing machine during the cycle.
- Do not allow counterweights or any other foreign bodies to enter the baseplate: they would stop the balancing machine functioning properly.
- Never use the balancing machine for any other purpose than those explicitly contained in this manual.
- The balancing machine can work at two speeds (low "I" and high "II"). You should normally use the low speed. It is possible to balance most vehicle wheels with this speed (~600 rpm). In the case of drive wheels with an especially hard differential, this speed may not be enough for the balancing machine to supply data, as the wheel slows down too quickly. In this case, use the vehicle motor .

N.B.

- 1) It is not necessary to spin the wheel at max. speed.
- 2) Working life of the motor could be impaired by insisting with it set to obtain maximum speed.
- 3) MOTOR START-UP: always start the motor in **I** mode and with the spinner properly in contact with the tyre. The mode **II** is used only rarely and in all cases only after reaching a good speed in **I** mode. A direct use of the spinner in the mode **II** would burnt out the motor after a few manoeuvres, even if the auxiliary cooling motor is operated.
- 4) WHEEL STOP: preferably the wheel should be stopped using the truck brake as use of the spinner with regenerative braking would be hazardous for the operator; never, under any circumstance, use it in the **II** mode, otherwise there is risk of burning out the motor after a few manoeuvres.
- 5) BALANCING MACHINE STAND-BY: never switch off the machine immediately after a balancing cycle as this would not allow the auxiliary cooling motor to operate.

- NOTE FOR THE PHOTO-ELECTRIC CELL: Keep the glass in front of the photo-electric cell clean, but without ever using corrosive liquids.

1.2 - Fields of application

- It is fast and easy to use and very accurate for all kinds of car or goods vehicle.
- The machine can balance two wheels at the same time, without having to move anything, by adding a transducer and a repeater for the photo-electric cell (optional):
 - * using the vehicle's own motor, you can balance both the front wheels in just two test spins (and all four wheels of a four-wheel drive in four spins);
 - * using the balancing machine's roller for the spin, you can balance both the wheels of a vehicle with front wheel drive, without having to move the machine from one side of the car to the other. The wheel on the other side is set in motion by the differential.
- A new infrared photo-electric cell for detecting the unbalance position (reference mark on the wheel). This system makes it easy for you to balance wheels whose tyres have white writing on the walls or with a white wall strip, which are becoming increasingly common in many countries all over the world.
- A height-adjustable photo-electric cell.
- An acoustic signal that tells the operator when he has reached the right test speed: the operator sits inside the vehicle when using the vehicle's own motor to provide the drive. This eliminates the need for delicate electronic panels that have to be transported to the driving seat and all the problems of connections.
- All the balancing operations are automated: the operator cannot make any mistakes.
- The second wheel on the same axle of the vehicle is balanced without having to run the self-calibration again.
- It is suitable for vehicles with two or four drive wheels and for goods vehicles.
- Measures unbalance to 1 gramme, the tolerance threshold to three grammes can be cut out by pressing a key.
- Spin speed reading.
- Speed reading, stored in the memory in the first self-calibration spin, which must be reached in later test spins.

1.3 - Overall dimensions

1

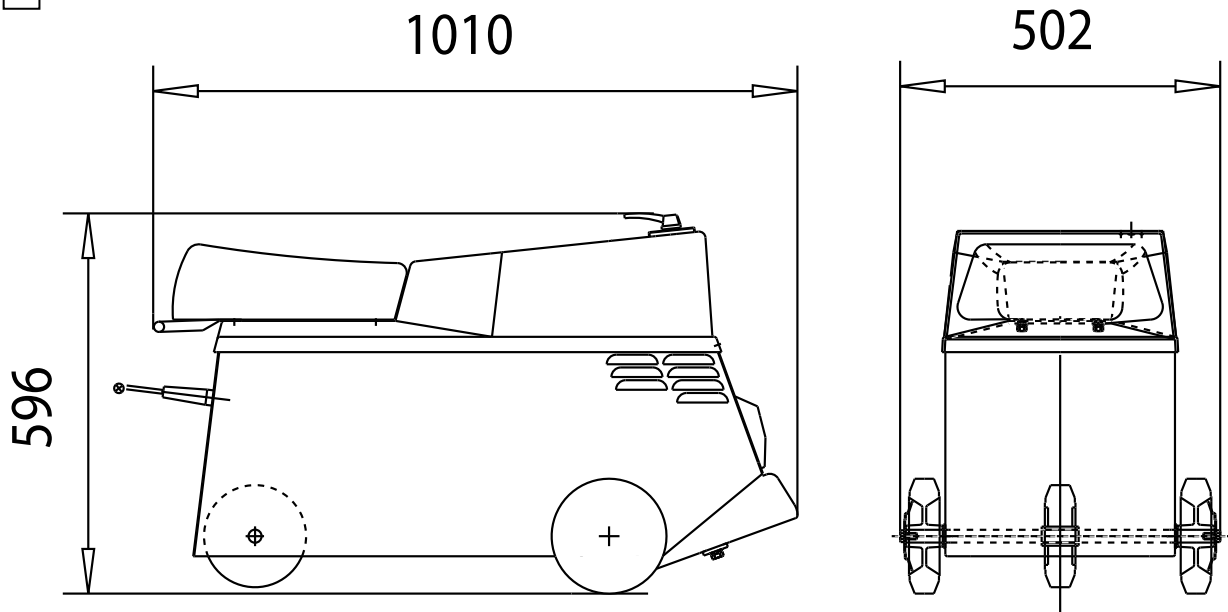

1.4 - Technical data

Angular accuracy	± 2.5°
Reading accuracy	± 1 g.
Max. power consumption	8,8 KW
Maximum wheel spin speed	140 Km/h
Maximum weight loadable on each TP2 car transducer	700 Kg
Maximum weight loadable on each TPT1 truck transducer	6000 Kg
Facility for balancing both wheels on the same axle at the same time	(optional)
Cabinet weight	64 Kg
External photo-electric cell weight	4 Kg
TP2 weight	19 Kg
TPT1 weight	28 Kg
Acoustic pressure level during cycle	<70 dB (A)
Working environment temperature	from 0 to 50°C

UNBALANCE DISPLAY RESOLUTION:

Grammes: Cars 1 g	Trucks 10 g
Ounces: Cars 0.25 oz.	Trucks 1.00 oz.

UNBALANCE DISPLAY THRESHOLD:

Grammes: Cars 3 g	Trucks 30 g
Ounces: Cars 0.25 oz	Trucks 2.00 oz.

2 - Moving the cabinet

The cabinet can be moved without much difficulty, as it is fitted on casters. A convenient handle fitted behind the saddle and the balanced weight of the front wheels make it easier to move.

3 - Power supply

NOTE: Power connections must be made by a specialist. A good earth connection is crucial for the machine to function properly.

CEMB cannot accept responsibility and its guarantee is null and void if the connections are not made properly.

The balancing machine is supplied by CEMB with a fixed power supply intake capacity, shown on the identification plate.

THIS VOLTAGE CANNOT BE CHANGED

Use the cable protruding from the rear of the balancing machine to make the power supply connection. We recommend that you connect the mains cable to an automatic safety switch in compliance with safety standards currently in force:

- power supply 3p. 440 V power consumption 20A
- power supply 3p. 400 V power consumption 22A
- power supply 3p. 230 V power consumption 38A

If you have to use an extension cable to connect the balancing machine to the mains, it must have the same diameter as the cable protruding from the balancing machine, i.e. 4 poles at 2.5 mm². Note that the motor always generates maximum power in position "II", while the current absorbed in position "I" is about 1/4 less. ALWAYS use position "I" when braking.

1b

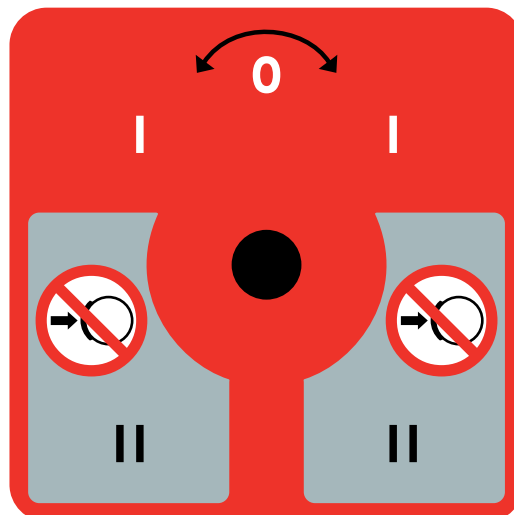

4 - Controls and functions

2 - CONTROL PANEL

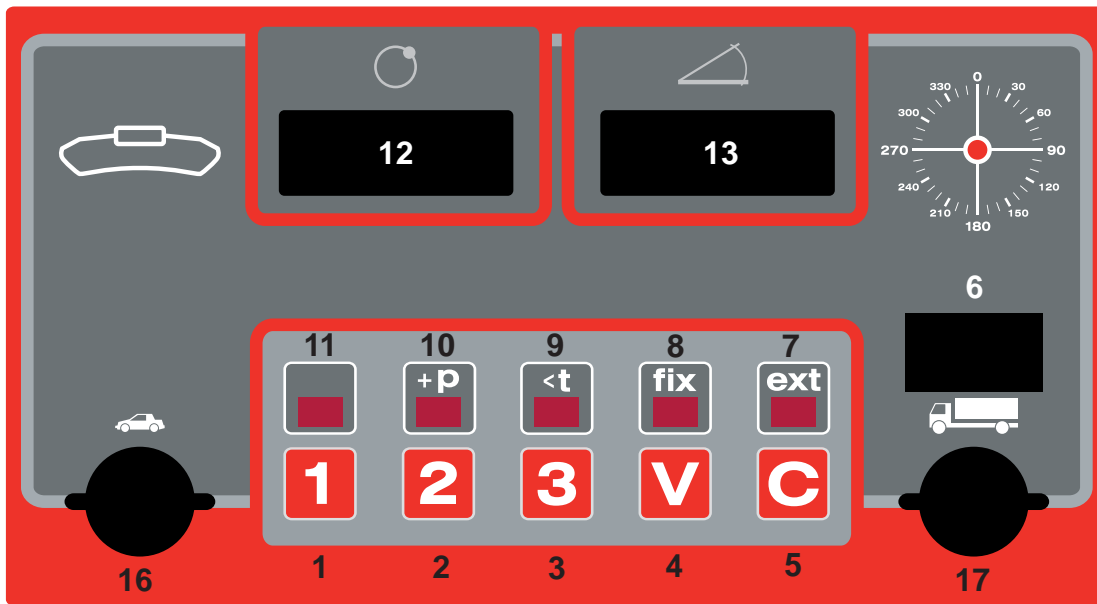

3 - CABINET

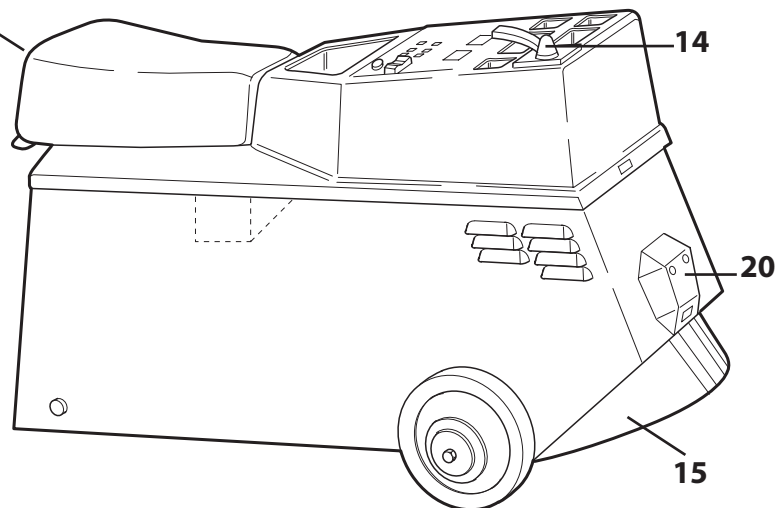

- 1 1st SPIN SELECTOR KEY
- 2 2nd SPIN SELECTOR KEY, displays reference weight
- 3 3rd SPIN SELECTOR KEY, displays threshold
- 4 CONSTANT SPEED SPIN SELECTOR KEY
- 5 PHOTO-ELECTRIC CELL SOCKET SELECTOR KEY
- 6 MAIN MEASUREMENT PANEL SWITCH
- 7 OPTION
- 8-9-10-11 LEDs INDICATING THE FUNCTION CURRENTLY ON
- 12 UNBALANCE VALUE DISPLAY
- 13 UNBALANCE ANGULAR POSITION DISPLAY, tachometer
- 14 MOTOR AND BRAKE CONTROL REVERSE SWITCH
- 15 WHEEL DRIVE PULLEY
- 16 CAR PICK-UP CONNECTION SOCKET
- 17 EXTERNAL TRUCK PICK-UP (and connection to PHOTO-ELECTRIC CELL SOCKET)

5 - Wheel balancing machine instructions

5.1 - Preparing for balancing

- Ensure that the vehicle bearings and suspension are in perfect condition. Any defects may make balancing difficult, sometimes impossible.
- When balancing drive wheels, ALWAYS lift both of them clear of the floor, to avoid damaging the differential. It is therefore a good idea to use two transducers.
- We recommend that you only balance the wheels after they have been used for several kilometres, so that the tyres have time to settle onto the wheel rims.
- Before starting to balance a wheel, make sure that it is fitted onto the vehicle correctly and that the rim has no deformities caused by accidents or for any other reason. A deformed wheel will give an uncomfortable ride and vibrations, even after perfect balancing.
You can check the wheel for deformations by turning it by hand and watching for any eccentricity and sidling in the tread. Before spinning the wheel, you should also remove any encrusted mud and check that the wheel turns freely.

5.2 - Positioning the pick-ups

- Lift the vehicle with an ordinary vehicle lift.
- Set the pick-ups as close to the wheel as possible and lower the vehicle until a part of the suspension rests stably on the pick-up holder.
- After this operation, ensure that the tyre is in contact with the central part of the balancing machine drive roller, in order to avoid damaging the tyre. Any variations in height can be taken care of by adjusting the rod of the pick-up holder.

4

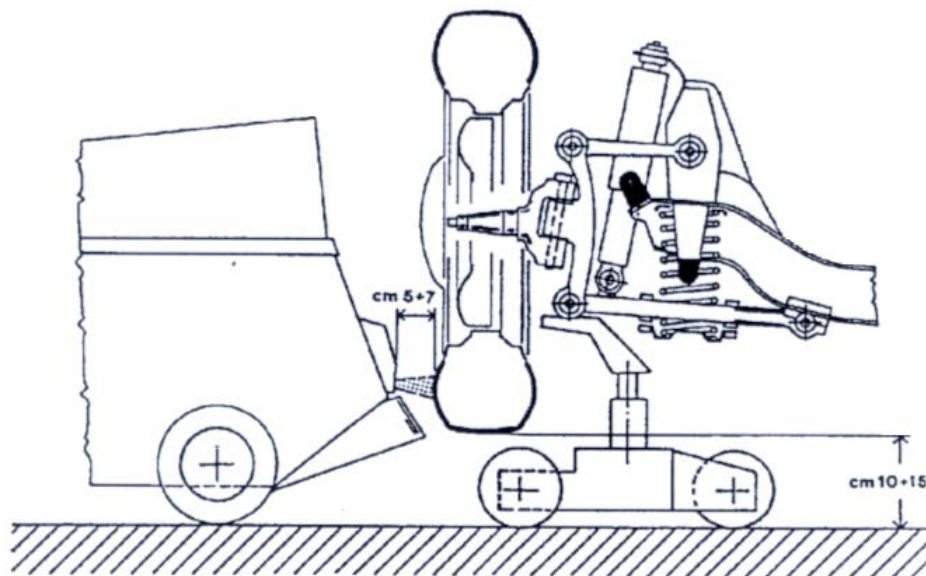

5.3 - Positioning the balancing machine

- After making the connections, guide the cabinet in front of the wheel to be balanced so that the machine is centered with the wheel.
- Make a white reference mark from the edge of the wheel rim to the outer edge of the tyre. If the wheel already has white lettering, use reflecting tape as a mark and keep it as far as possible from the white lettering.
- Adjust the height of the photo-electric cell so that it reads the white reference mark. Check that the photo-electric cell is at least 3 cm (maximum 7 cm) from the tyre when the pulley rests on the wheel.
- Use the cable provided to connect socket [16] on the panel with the car pick-up or socket [17] with the truck pick-up.

5.4 - Balancing non-drive wheels (Advised speed c. 600 rpm)

A - FIRST OPERATION

1. Set switch [6] to "ON". If the machine is already on, press key [1]. LED [11] will light up (spin 1).
2. Set pulley [15] in contact with the tyre.
3. Rotate the reverse switch to "I" to start the rotor turning (the wheel must rotate in the vehicle's forward direction).
4. Wait until a value of c. 600 shows up on display [13].
5. Remove pulley [15] to about 5 to 7 cm from the tyre.
6. Wait until displays [12] and [13] read some numbers, although you need not take these numbers into consideration (they indicate the unbalance value and phase with an accuracy comparable to that obtained from a stroboscopic machine).
7. LED [10] will now flash.
8. Stop the wheel, moving the pulley back onto the tyre and reversing the direction of the pulley's rotation (always stop on the low speed "I").

B - SECOND OPERATION

1. Apply 30 grammes (300 grammes for truck wheels) to the wheel rim in a place corresponding to the white reference mark.

5

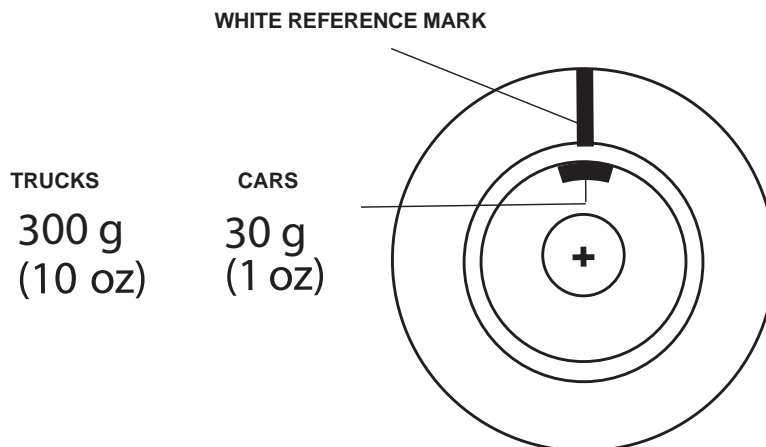

2. Spin the wheel again until display [12] reads "HI".
3. Remove the pulley and wait for the data to be displayed.
4. Stop the wheel by reversing the direction of rotation (low speed "I").
5. Display [12] will read the value of the real unbalance in grammes, while display [13] will read the angular position of the unbalance (PICKED-UP POSITION).
6. Remove the 30 gramme weight.

7. Set the wheel for correction

Rotate the wheel by hand and set the white reference mark in the position indicated by display [13] (follow the diagram at the top right of the panel to make this operation easier). Apply a weight whose value is indicated by display [12] to the top of the wheel (12 o'clock position).

6

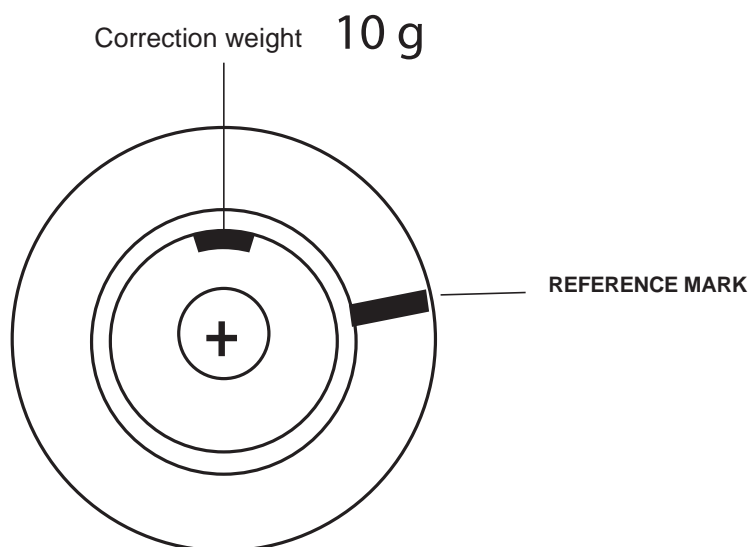
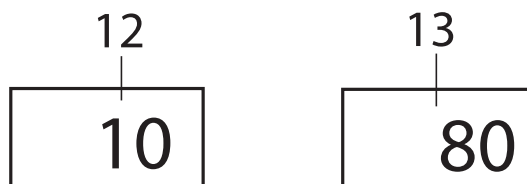

C - THIRD OPERATION (Check)

1. Spin the wheel until display [12] reads "HI".
2. Remove the pulley and wait for the data to be displayed.
3. Stop the wheel by reversing the direction of rotation (low speed "I").
4. Display [12] will read the value of the residual unbalance (if the preceding operations have been carried out well, the value read out should be "00" or in any case a tolerable unbalance value).
5. If the piece has not been balanced enough, correct the unbalance in accordance with the information shown on the instruments. Follow point B to determine how to read the unbalance position.

5.5 - Important notes

CALIBRATION WEIGHT

The machine's computer considers the calibration counterweight applied for the second test spin to be equal to 30 grammes (300 grammes for a truck). In some cases, you may find it useful to use different counterweights, but remember that you will then have to correct the final readings as a result.

For example:

- **Light trucks:** the 300 gramme counterweight is too heavy, as it makes the wheel jump. You can use a 100 gramme counterweight and divide the final reading by three.

- Finishing on already balanced automobile wheels

In this case, you may find it useful to apply a 15 gramme counterweight. This way, you will have an unbalance reading that is double the value of the unbalance to be added. There are two advantages to this system: firstly greater sensitivity and secondly less risk of making the wheel jump, especially by using pick-ups not mounted on a rigid tripod (e.g. on a hydraulic jack).

5.6 - Balancing drive wheels using the balancing machine motor (Advised speed c. 1200 rpm)

IMPORTANT NOTE

Before starting to balance, it is very important you ensure that the wheels, which must both be lifted clear of the floor, are free to turn and have no strong drag, which would make them difficult to spin. **In this case, the wheels must be spun using the vehicle motor (see *BALANCING DRIVE WHEELS USING THE VEHICLE MOTOR*).** If the wheel presents too much resistance to the balancing machine motor, the balancing machine itself will inform the operator by displaying the read-out "HELP-05" after the first spin. If you insist on spinning hard wheels with the balancing machine motor, you may cause serious damage to the vehicle differential.

A - FIRST OPERATION

1. Set switch [6] to "ON". If the machine is already on, press key [1]. LED [11] is lit up.
2. Move pulley [15] into contact with the tyre.
3. Turn the reverse switch to "I" to set the wheel spinning (the wheel must rotate in the vehicle's forward direction). You can pass to "II" to reach the desired speed if necessary.
4. Wait until display [13] reads a value of c. 1200 rpm.
5. Remove pulley [15] to about 5 to 7 cm from the tyre.
6. Wait until displays [12] and [13] read some numbers. You need not take the numbers on the displays into consideration (they indicate the unbalance value and phase with an accuracy comparable to that obtained from a stroboscopic machine).
7. LED [10] will now flash.
8. Stop the wheel by moving the pulley back onto the tyre and reversing the direction of rotation on the low speed "I".

B and C - SECOND and THIRD OPERATIONS

Follow the sequence described for non-drive wheels.

5.7 - Balancing drive wheels using the vehicle motor

- Set the balancing machine in front of the wheel to be balanced with pulley [15] set at about 3 cm from the tyre.
- Set switch [6] to "ON".
- Press key [V] (measurement at a constant speed).
- LEDs [11] and [8] will light up (spin 1 and constant speed).

FIRST SPIN

- Start up the vehicle motor and select the fastest gear; set the wheels spinning and accelerate until the speedometer reads c. 120 km/h. If you notice excessive vibration, vary the speed slightly.
- Keep this speed constant until you hear a long BEEP sound (if you hear a short BEEP sound, this means that the speed has not been kept constant). Keep the speed constant as long as the BEEP sounds.
- Stop the wheels and add a 30 gramme weight on the white reference mark on the wheel being balanced.

SECOND SPIN

- Start the wheels up, using the vehicle motor again, and bring the vehicle to the same speed as before (c. 120 km/h).
- A long BEEP sound indicates that the vehicle has reached this speed (if you hear a short BEEP sound, this means that the speed of the first spin has not been reached, so you must accelerate or decelerate a little). Keep the speed constant as long as the BEEP sounds.
- Stop the wheels.
- Display [12] will read the unbalance value in grammes, while display [13] will read the position of the unbalance picked up.
- Make the correction as already explained in the paragraph on BALANCING NON-DRIVE WHEELS, starting from point B6.

6 - Errors

While the machine is in use, there may be various causes of malfunction. If the microcomputer picks them up, the left hand (unbalance) display will read "HELP" and the right hand (phase) display will read a number corresponding to the following meaning:

ERROR	MEANING
03	Signal from pick-up too strong. Reduce measurement speed.
04	Rotation in opposite direction to spin 1.
05	Rotation too slow.
06	Rotation too fast.
07	The photo-electric cell cannot read the reference mark correctly.
08	Sharp wheel deceleration during measurement.
09	Spin 2 was carried out without adding the reference weight, or the pick-up has been disconnected or has a short circuit.
10	As per error 09, but refers to the external pick-up when the two wheels are being measured simultaneously at a constant speed.

7 - Ordinary maintenance (Non-specialised staff)

The photo-electric cells are one of the machine's most important and delicate elements. For this reason, we recommend you take care to keep the transparent glass mask clean. Do not use liquids that contain solvents.

8 - Recommended spare parts list

CODE	DESCRIPTION
681000800	Fuse
940513011	Power card
611016684	50UA Tranformer
940512916	Processor card
513553725	switch/inverter
940602919	Complete phases
940512913	Phases card
50MM58311	3-phase 230V 50-60 Hz motor
50MM58310	3-phase 400V 50-60 Hz motor