

## CONTENTS

|  |           |
|--|-----------|
| <b>1 - GENERAL</b>   | <b>3</b>  |
| 1.1 - GENERAL SAFETY REGULATIONS   | 3         |
| 1.1.1 - STANDARD SAFETY DEVICES  | 3         |
| 1.2 - FIELD OF APPLICATION   | 3         |
| 1.3 - OVERALL DIMENSIONS   | 3         |
| 1.4 - TECHNICAL DATA   | 4         |
| <b>2 - HANDLING AND LIFTING</b>  | <b>4</b>  |
| <b>3 - START - UP</b>  | <b>4</b>  |
| 3.1 - ANCHORING  | 4         |
| 3.2 - ELECTRICAL CONNECTION  | 5         |
| 3.3 - PNEUMATIC CONNECTION (MODEL SE)  | 5         |
| 3.4 - FURTHER SAFETY DEVICES (MODEL SE)  | 5         |
| 3.5 - ADAPTER MOUNTING   | 5         |
| 3.6 - WHEEL GUARD ASSEMBLY AND ADJUSTMENT (OPTION)                               | 8         |
| 3.7 - WD/DC SPACER (OPTIONAL)  | 8         |
| <b>4 - CONTROLS AND COMPONENTS</b>   | <b>8</b>  |
| 4.1 - WHEEL LOCKING (SE VERSION)   | 8         |
| 4.2 - BRAKE PEDAL  | 8         |
| 4.3 - PNEUMATIC LOCKING PEDAL (SE VERSION)                                       | 9         |
| 4.4 - AUTOMATIC DISTANCE AND DIAMETER GAUGE                                      | 9         |
| 4.4.1 - DISTANCE GAUGE LOCKING (SE VERSION)                                      | 9         |
| 4.5 - AUTOMATIC WIDTH GAUGE  | 9         |
| 4.6 - CONTROL PANEL AND DISPLAY  | 10        |
| 4.6.1 - OPERATION FUNCTIONS MENU   | 11        |
| 4.6.2 - OPPOSITE POSITION  | 12        |
| 4.6.3 - STATIC ALWAYS ENABLED  | 12        |
| <b>5 - INDICATION AND USE OF THE WHEEL BALANCER</b>                              | <b>12</b> |
| 5.1 - DOUBLE OPERATOR PROGRAM  | 12        |
| 5.2.1 - DATA SETTING   | 13        |
| 5.3 - AUTOMATIC PRESETTING   | 13        |
| 5.3.1 - STEEL OR ALUMINUM WHEEL RIMS. SPRUNG COUNTERWEIGHTS                      | 13        |
| 5.3.1.1 - AUTOMATIC WIDTH (OPTION)   | 14        |
| 5.3.1.2 - STATIC & COMBINED MODES  | 14        |
| 5.3.2 - RIMS WITH INTERNAL COUNTERWEIGHT   | 14        |
| 5.4 - RESULT OF MEASUREMENT  | 15        |
| 5.4.1 - IC CORRECTION METHOD   | 15        |
| 5.5 - RECALCULATION OF THE UNBALANCE   | 15        |
| 5.6 - EXACT POSITIONING OF THE ADHESIVE WEIGHT BY MEANS OF THE GAUGE WITH CLIPS  | 15        |
| 5.7 - SPLIT FUNCTION (HIDDEN ADHESIVE WEIGHTS)                                   | 17        |
| 5.8 - UNBALANCE OPTIMIZATION   | 18        |
| 5.9 - AUTOMATIC MINIMIZATION OF STATIC UNBALANCE                                 | 19        |
| 5.10 - ECCENTRICITY MEASUREMENT  | 19        |
| <b>6 - SET UP</b>  | <b>20</b> |
| 6.1 - AUTO-DIAGNOSTICS   | 20        |
| 6.2 - SELF-CALIBRATION   | 20        |
| 6.3 - MANUAL DIMENSION PRESETTING (Use only in particular cases or for test)     | 21        |
| 6.3.1 - STEEL WHEEL RIMS (USE FOR SETTING DIMENSIONS IN <b>AUTOCALIBRATION</b> ) | 21        |
| 6.3.2 - ALUS RIMS  | 21        |
| 6.3.2.1 - ALUS VARIANT WITH INSIDE CLAMP WEIGHT                                  | 22        |
| 6.4 - WHEEL LOCKING  | 23        |

|                                       |           |
|---------------------------------------|-----------|
| 6.5 - GAUGE LOCKING                   | 23        |
| 6.6 - SPIN TYPE                       | 23        |
| 6.7.1 - RIM DISTANCE GAUGE            | 24        |
| 6.7.2 - DIAMETER GAUGE                | 25        |
| 6.7.3 - WIDTH SONAR                   | 26        |
| <b>7 - ERRORS</b>                     | <b>27</b> |
| 7.1 - INCONSISTENT UNBALANCE READINGS | 28        |
| <b>8 - ROUTINE MAINTENANCE</b>        | <b>28</b> |
| 8.1 - TO REPLACE THE FUSES            | 28        |

## 1 - GENERAL

### ► 1.1 - GENERAL SAFETY REGULATIONS

- The machine should only be used by authorized and suitably trained personnel.
- Do not use the machine for purposes other than those specified in this manual.
- The machine should not be modified in any way except for those modifications explicitly carried out by specialised personnel.
- Never remove the safety devices. Any work on the machine should only be carried out by specialised personnel.
- Avoid using strong jets of compressed air for cleaning.
- Use alcohol to clean the plastic panel or shelves (AVOID LIQUIDS CONTAINING SOLVENTS).
- Before starting the wheel balancing cycle, make sure that the wheel is securely locked on the adapter.
- The machine operator should avoid wearing clothes with flapping edges. Make sure that unauthorized personnel do not approach the machine during the work cycle.
- Avoid placing objects inside the cabinet as they could impair the correct operation of the machine.

#### ► 1.1.1 - STANDARD SAFETY DEVICES

Stop key that stops the motor when an emergency arises.

### ► 1.2 - FIELD OF APPLICATION

The machine is designed for balancing wheels of car, light commercial vehicles or motorcycle, weighing less than 75 Kg. It can be operated in the temperature range of 0° to + 45°C.

### ► 1.3 - OVERALL DIMENSIONS

1

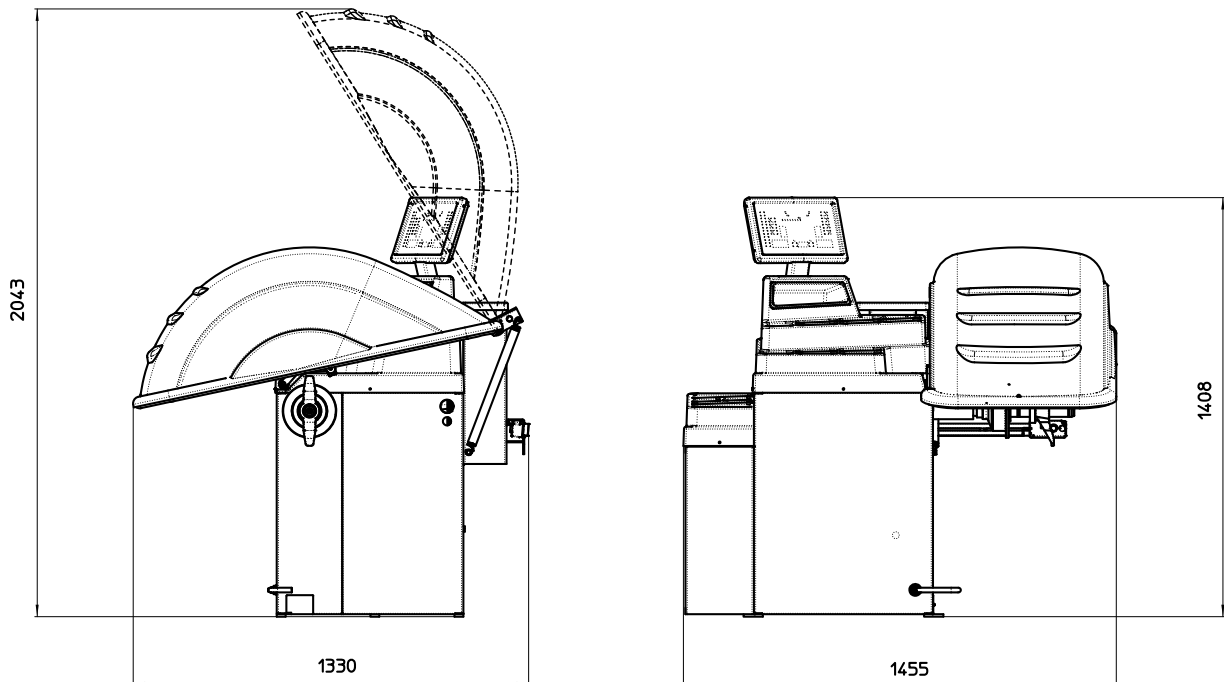

## ► 1.4 - TECHNICAL DATA

|  |                                |
|--|--------------------------------|
| Single-phase power supply              | 115 / 230 V 50/60 Hz           |
| Protection class                       | IP 54                          |
| Max.power consumption                  | 1,1 Kw                         |
| Balancing speed                        | 180 min <sup>-1</sup>          |
| Cycle time for average wheel (14 kg)   | 6-8 seconds                    |
| Max.resolution of measurement          | 1 gram                         |
| Position resolution                    | ± 1.4 °                        |
| Average noise                          | < 70dB (A)                     |
| Rim-machine distance                   | 0 - 255 mm                     |
| Rim width setting range                | 1.5" ÷ 20" or 40 ÷ 510 mm      |
| Diameter setting range                 | 10" ÷ 30" or 265 ÷ 765 mm      |
| Min/max. compressed air pressure       | 8 ÷ 10 Kg/cm <sup>2</sup>      |
|  | approx. 0.8 to 1 Mpa;          |
|  | approx. 8 to 10 BAR;           |
|  | approx. 115 to 145 PSI.        |
| Air consumption for wheel lock/release | 4 lt. (8 Kg./cm <sup>2</sup> ) |

## 2 - HANDLING AND LIFTING

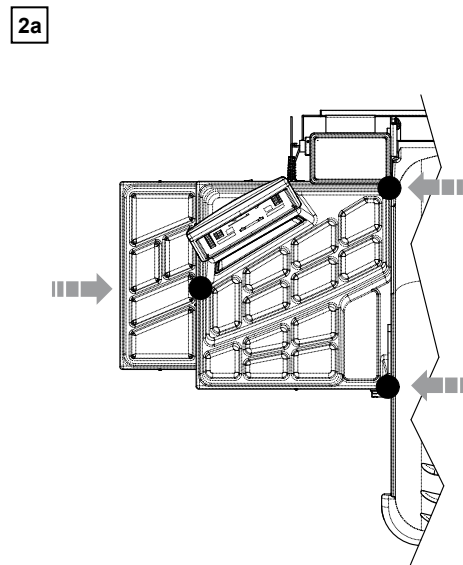
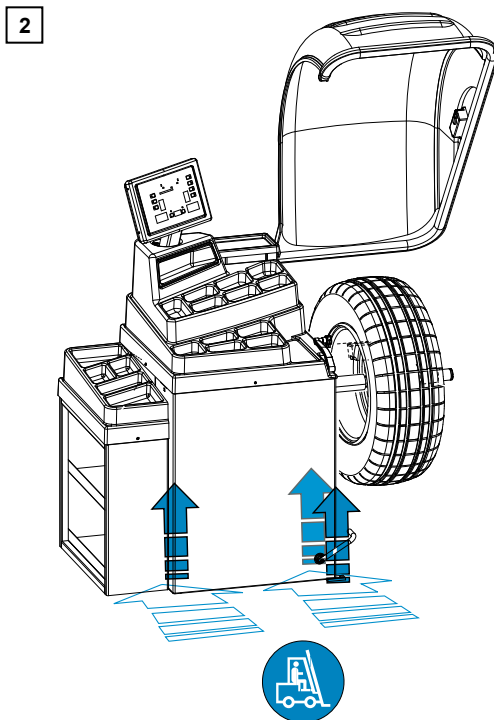

**NOTE: NEVER USE OTHER POINTS TO LIFT THE MACHINE.**

## 3 - START - UP

### ► 3.1 - ANCHORING

The machine can operate only on flat non resilient floor. Make sure that the machine rests on the 3 mounting points provided (Fig. 2).

**N.B.:** *If possible, it is advisable to anchor to the floor using relative mounting feet (see fig. 2a) if the machine is continually used with wheels weighing over 35 kg.*

### ► 3.2 - ELECTRICAL CONNECTION

The machine is supplied with a single- phase mains cable plus earth (ground).

The power supply voltage (and mains frequency) is indicated on the machine identification plate and cannot be changed. Connection to the mains must always be made by expert personnel.

The machine must not be set up without proper earthing.

Connection to the mains should be through a slow acting safety switch rated at 4A (230V) or 10A (115V). See enclosed diagram.

### ► 3.3 - PNEUMATIC CONNECTION (Model SE)

For operation of the spindle with pneumatic locking (constant thrust air spring) connect the wheel balancer to the compressed air mains. The connection fitting is located at the back of the machine. At least 8 Kg/cm<sup>2</sup> (~ 0.8 MPa; ~ 8 BAR; ~ 100 PSI) pressure is needed for correct operation of the release device.

### ► 3.4 - FURTHER SAFETY DEVICES (Model SE)

- Wheel always locked even when there is pressure failure during the balancing cycle.

- Always actuate the unlocking control pedal with the machine stopped in order to avoid stress and abnormal wear on the adapter.

### ► 3.5 - ADAPTER MOUNTING

The wheel balancer is supplied complete with cone type adapter for fastening wheels with central bore. Other optional flanges can be mounted once the terminal part is removed (also see enclosed brochures).

**N.B.: CAREFULLY CLEAN THE COUPLING SURFACES BEFORE PERFORMING ANY OPERATION.**

#### DISASSEMBLY OF THE THREADED END PIECE

- a) Loosen screw B and remove threaded end-piece A.
- b) Mount the new adapter.

3

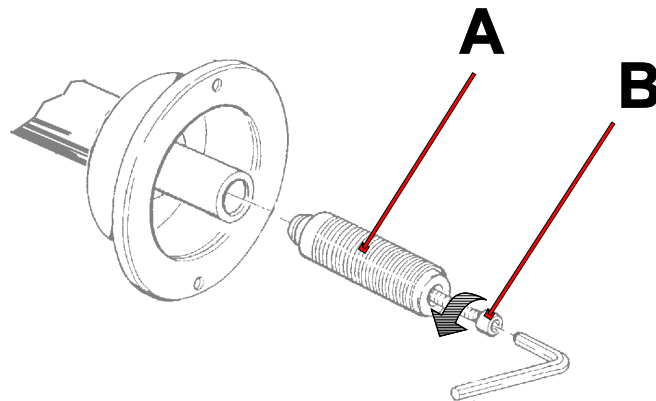

# SE2-Mounting

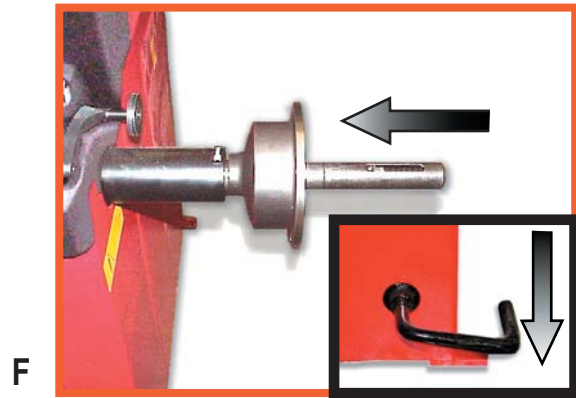
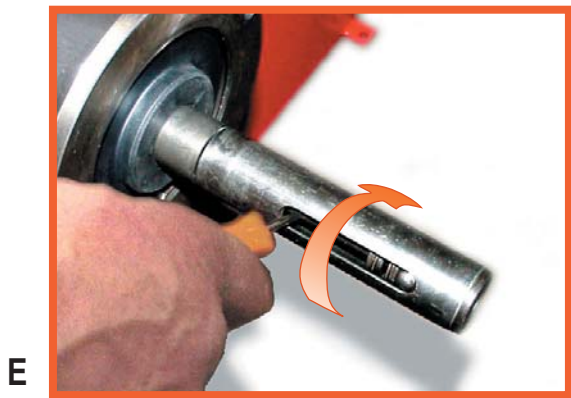
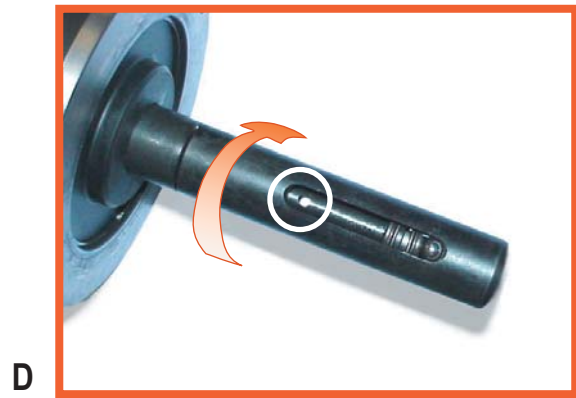
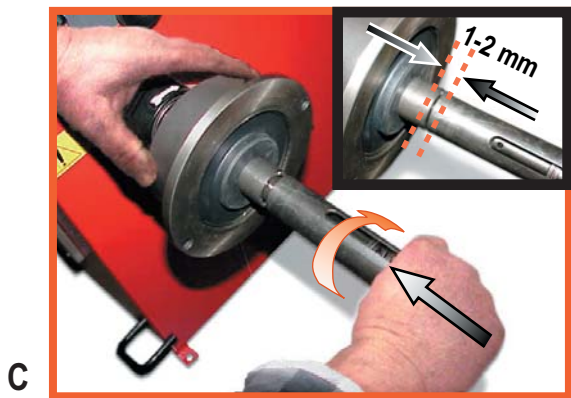
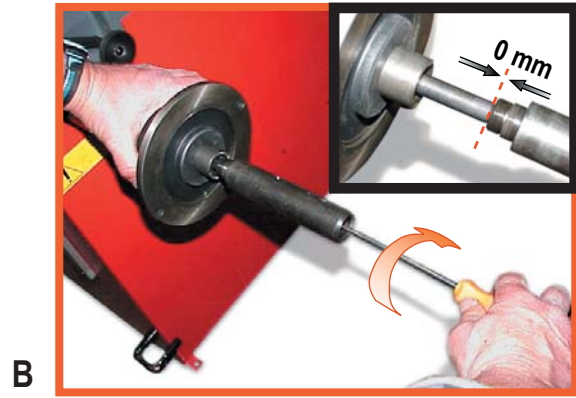
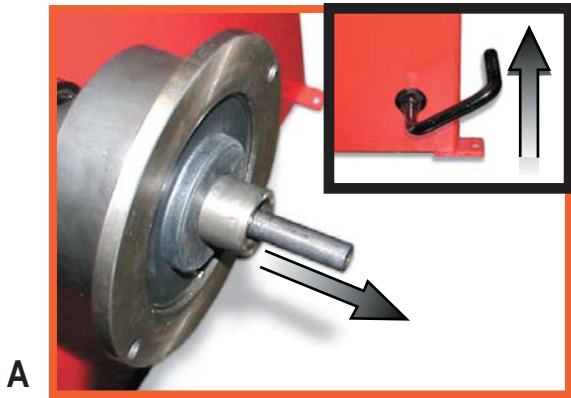

# SE2-Dismounting

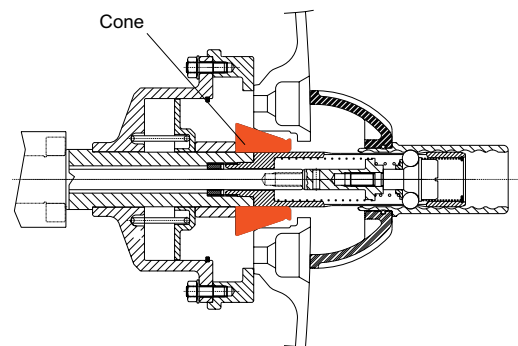
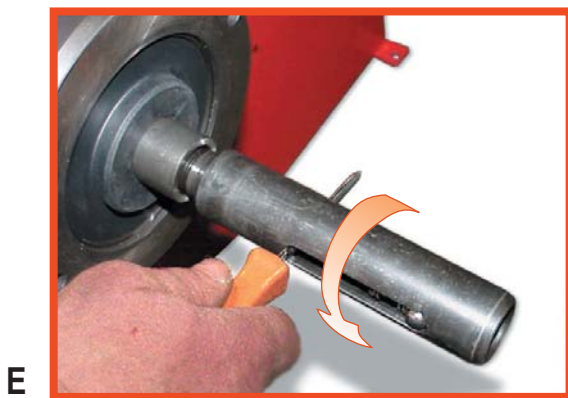
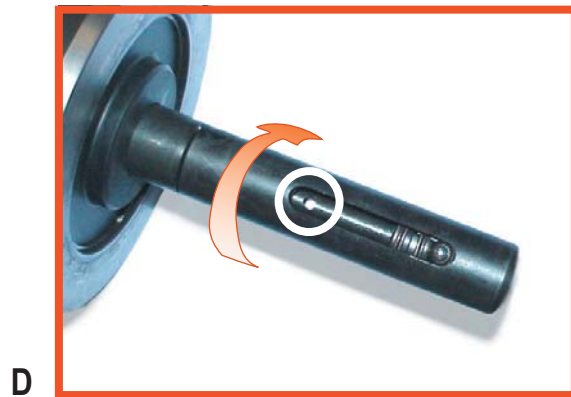
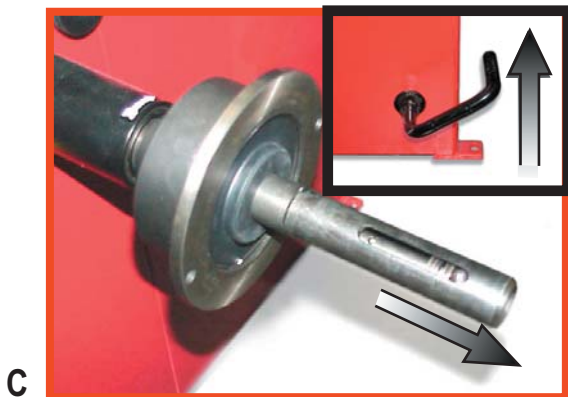
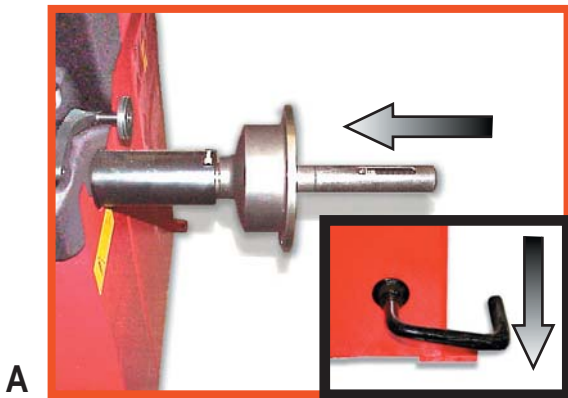

- Quando possibile, centrare le ruote con cono dall'interno (vedi disegno).
- Evitare di usare il manicotto RL con cerchi di ferro.
- Whenever possible, centre the wheels with the cone from the inside (see the drawing).
- Avoid using the RL sleeve with metal rims.
- Lorsque c'est possible, centrer les roues avec le cône de l'intérieur (voir dessin).
- Eviter d'utiliser le manchon RL avec les jantes en fer.
- Wenn möglich, die Räder mit Konus von Innen heraus zentrieren (siehe Zeichnung).
- Bei Eisenfelgen die Verwendung der Muffe RL vermeiden.
- Siempre que sea posible, centrar las ruedas con cono desde dentro (véase dibujo).
- Evitar usar el manguito RL con llantas de hierro.
- Quando possível, centre as rodas com cone pelo lado de dentro (ver figura).
- Evite utilizar a luva RL com jantes de ferro.

### ► 3.6 - WHEEL GUARD ASSEMBLY AND ADJUSTMENT (option)

- a) Fasten the components to the base as illustrated in the specific exploded drawing.
- b) Check that the microswitch is held down when the guard is closed.
- c) Adjust the angular position of microswitch control ring.

## 4 - CONTROLS AND COMPONENTS

### ► 4.1 - WHEEL LOCKING (SE version)

The wheel is automatically locked when reaching the correct angular position for weight application on the inside and outside, turning it slowly by hand. To unlock the wheel, turn it hard to move it from the correct correction position. If the unbalance is within tolerance, the wheel is not automatically locked.

Pressing the  button the chuck can be locked/released in any position to facilitate mounting the wheel.

### ► 4.2 - BRAKE PEDAL

4

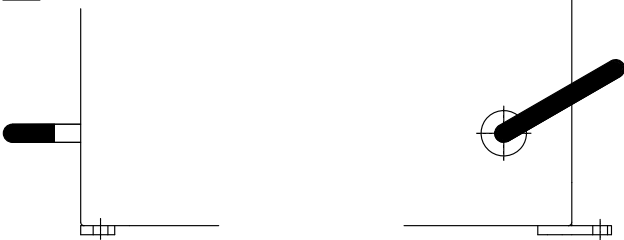

It allows the operator to keep the wheel stopped when fixing the counterweights. **It must not be used during the measuring cycle.**

### ► 4.3 - PNEUMATIC LOCKING PEDAL (SE version)

5



It allows the fixing/releasing of the wheel on the flange. **It must not be used during the machine cycle and/or when different flanges are mounted from that with standard cones. The pedal has two stable positions:** upper position for unlocking; lower position for locking the wheel.

### ► 4.4 - AUTOMATIC DISTANCE AND DIAMETER GAUGE

Allows measuring the distance from the machine and the diameter at the point of application of the counterweight. The same gauge allows proper positioning of the counterweights inside using the specific function which allows reading on the display the position used for the measurement within the rim.

#### ► 4.4.1 - DISTANCE GAUGE LOCKING (SE version)

The distance gauge is automatically locked when the adhesive weights have reached the correct application distance. To release the gauge, lower it to below 10" diameter.

#### ► 4.5 - AUTOMATIC WIDTH GAUGE (option)

Width gauging is through a SONAR device which measures the width of the wheel without mechanical contact, simply by closing the guard and each time a valid measurement has been made with the gauge.

► **4.6 - CONTROL PANEL AND DISPLAY**

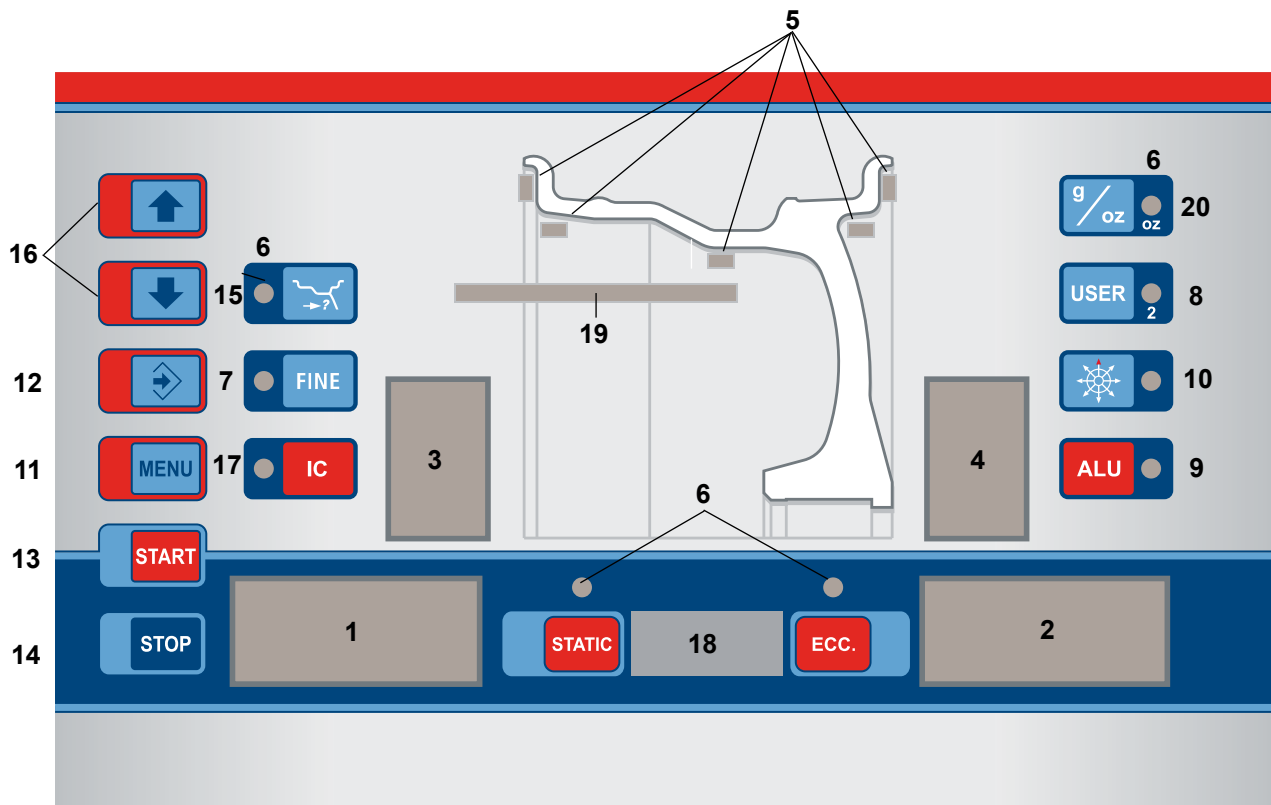

- 1-2 Digital readouts, AMOUNT OF UNBALANCE, inside/outside
- 3-4 Digital readouts, POSITION OF UNBALANCE, inside/outside
- 5 Indicators, correction mode selected
- 6 Indicators, selection made
- 7 Push button, unbalance reading < 5 g (25 oz)
- 8 Push button, operator selection
- 9 Push button, selection of mode of correction
- 10 Push button, SPLIT (unbalance spread)
- 11 Push button, FUNCTIONS MENU
- 12 Push button, menu selection confirmation
- 13 Push button, cycle start
- 14 Push button, emergency/home
- 15 Push button, position repeater
- 16 Manual dimension setting buttons (only possible after specific activation)
- 17 Push button, IC correction method selection
- 18 Wheel static/eccentricity imbalance display
- 19 Indicator, distance gauge position
- 20 Push button, grams/ounces selection

**Note:** Only use the fingers to press the push buttons. Never use the counterweight pincers or other pointed objects.

► 4.6.1 - OPERATION FUNCTIONS MENU

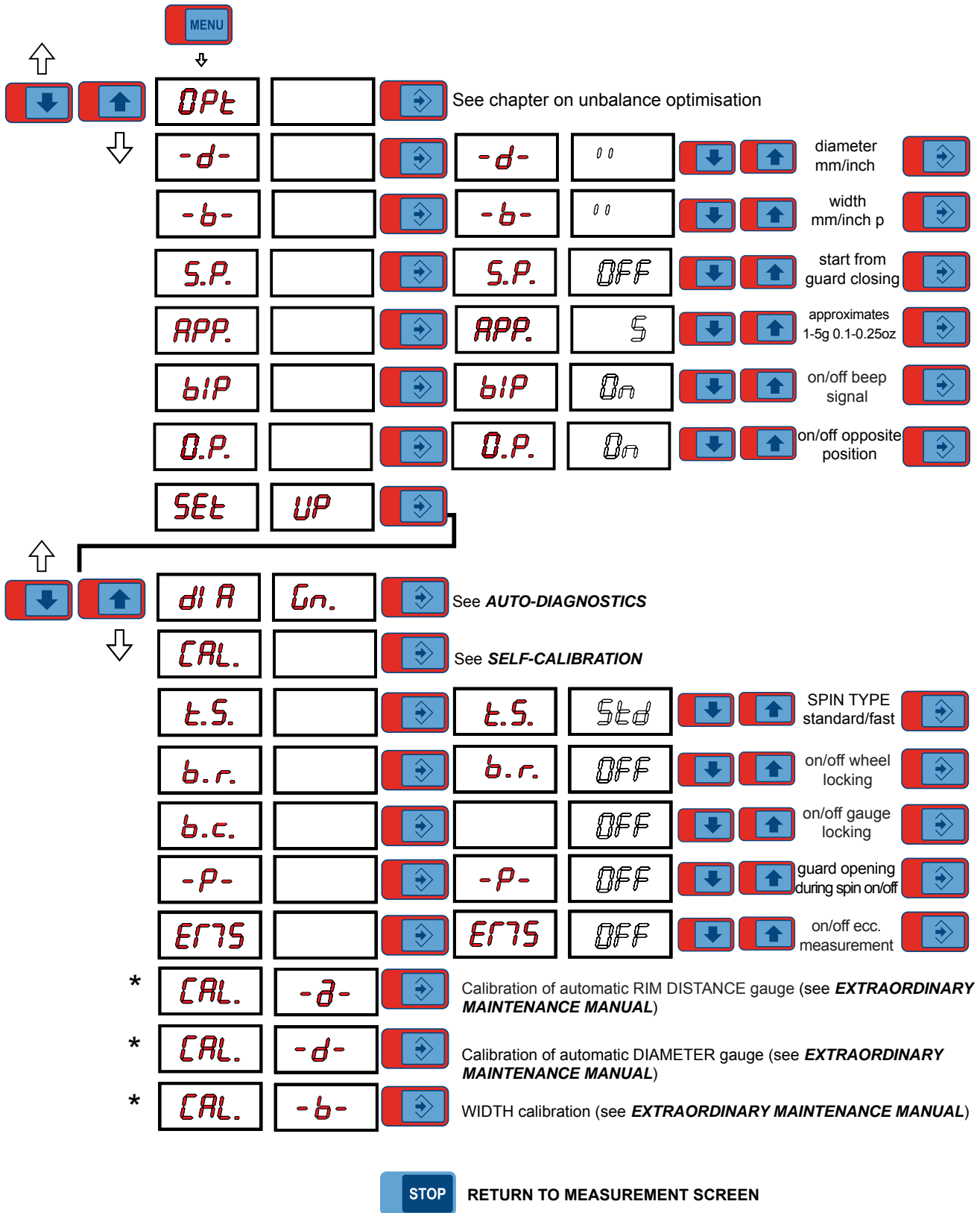

\* N.B. If such indications fail to appear, contact Technical Service.

#### ► 4.6.2 - OPPOSITE POSITION

The normal balancing condition requires the correction weights to be applied at the top (12 o'clock) when the symbol is displayed:

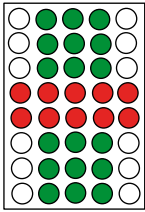

Apply the correction weight at the top (12 o'clock)

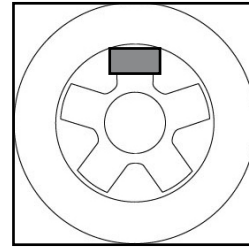

If OPPOSITE POSITION is enabled, the phase displays also indicate the weight application position at the bottom (6 o'clock) to facilitate cleaning the rim and the relative application of adhesive weights. The symbol used is:

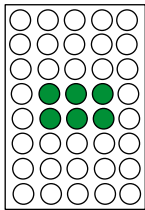

Apply the correction weight at the bottom (6 o'clock)

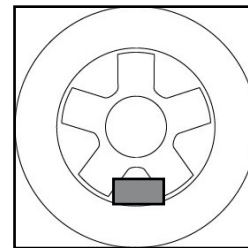

#### ► 4.6.3 - STATIC ALWAYS ENABLED

To enable permanent display of the static imbalance on the central display, press button  (the corresponding LED comes ON).

To obtain also the static imbalance phase, select the STATIC correction method by pressing the button .

## 5 - INDICATION AND USE OF THE WHEEL BALANCER

### ► 5.1 - DOUBLE OPERATOR PROGRAM

This program allows memorizing the dimensions of two types of wheels. Thus two operators can work simultaneously on two different cars using the same balancing machine. The system memorizes two programs with various present dimensions.

1 - Press  to select the operator (1 or 2).

2 - Enter the dimensions

3 - Press  to carry out the balancing as usual and to automatically store the program to the currently selected user.

Press  to select program 1 or 2 for subsequent balancing operations without setting the dimensions again.

## 5.2 - USING THE GAUGE INSTALLED ON THE MACHINE

### ► 5.2.1 - DATA SETTING

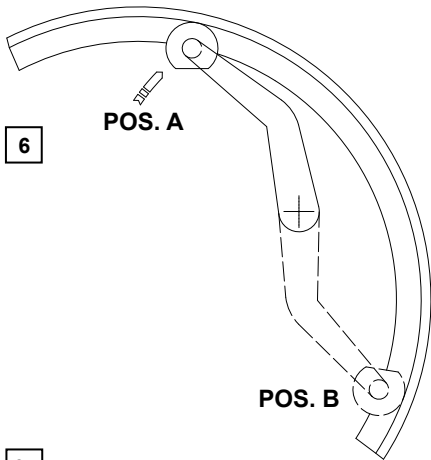

For clamp weights, use the gauge in the top position A.  
For adhesive weights, use the gauge as preferred in top position A or bottom position B.

*Note: Always use the round part of the striker plate resting on the rim.*

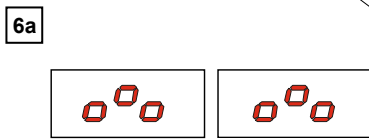

Indication of gauge in movement

### ► 5.3 - AUTOMATIC PRESETTING

The machine automatically detects the correct balancing program for steel and aluminium rims.

The counterweight position proposed may be changed using the **ALU** button.

#### ► 5.3.1 - STEEL OR ALUMINUM WHEEL RIMS. SPRUNG COUNTERWEIGHTS

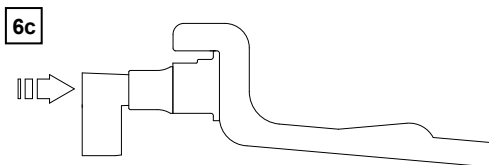

Pull out the gauge as far as the inner edge of the rim. Hold it in this position until the symbol shown in Fig. 6d is displayed.

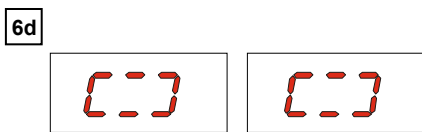

Indication of dimensions acquired  
Return the gauge to rest position. The machine has automatically detected DISTANCE + DIAMETER and goes to MANUAL WIDTH SETTING.

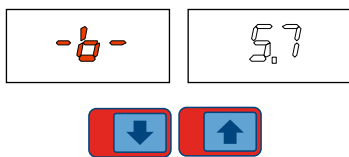

- The nominal width is normally stamped on the rim; if not, proceed to measure dimension "b" with the calibre gauge (supplied as standard).

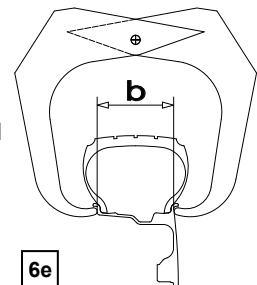

► **5.3.1.1 - AUTOMATIC WIDTH (option)**

At the end of the automatic measurement of the distance and diameter the following appears:



For large wheels (e.g. off-road vehicles, light trucks or wheels protruding far out from the rim) press the  button to switch from:

N.T. = NORMAL TYRE

L.T. = LIGHT TRUCK

Slowly close the wheel guard until a “beep” is heard.

If "AUTOMATIC START" is enabled when the guard is closed, the balancing machine performs a cycle to measure the imbalance, otherwise the width value just acquired is shown.

Press the button  to perform a spin.

► **5.3.1.2 - STATIC & COMBINED MODES**

After calibration as per **STEEL OR ALUMINUM WHEEL RIMS. SPRUNG COUNTERWEIGHTS**, it is possible to modify the position of the correction weights using the  button.

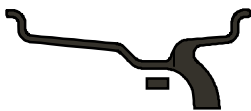

STATIC



Balancing of light alloy rims with application of adhesive weights on the shoulders of the rims.



Combined balancing: adhesive weight on the outside and clip-on weight on the inside.



Combined balancing: adhesive weight on the inside and clip-on weight on the outside.

► **5.3.2 - RIMS WITH INTERNAL COUNTERWEIGHT**

7

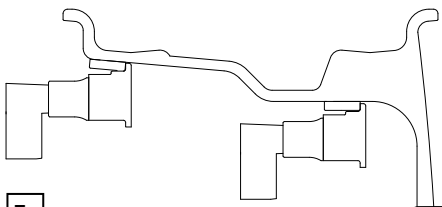

Slide out the gauge on the LH side, at the point where a weight is to be fitted. Wait until the symbol shown in Figure 6d is displayed. Pull it out further towards the right plane and wait until the symbol shown in Figure 7a is displayed. The wheel balancer automatically identifies ALUS mode.

7a



Counterweight position automatically suggested.

7b

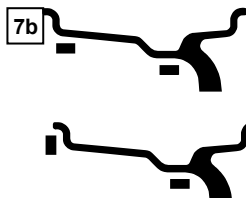

 can be used to set the alternative position indicated.

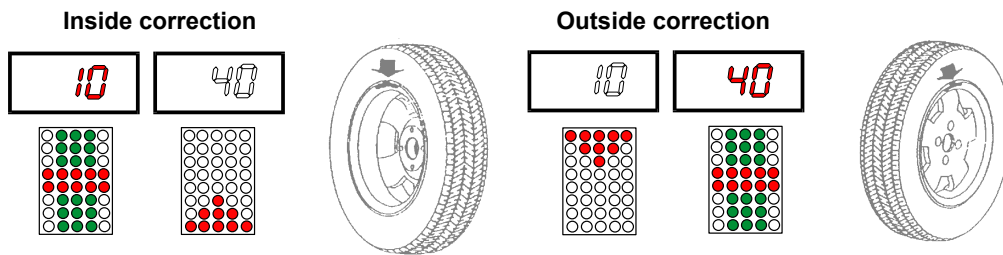

## ► 5.4 - RESULT OF MEASUREMENT



After performing a balancing spin, the amounts of unbalance are shown on the digital readouts.

Digital readouts with LED 's 3 - 4 lit up indicate the correct angular wheel position to mount the counterweights (12 o'clock position). If the wheel clamp option is enabled (see **OPERATION FUNCTIONS MENU**), the wheel is automatically clamped in the correction position.

If the unbalance is less than the threshold selected, 0 is displayed instead of the unbalance; with  it is possible to read the values below the threshold chosen gram by gram.

It is also possible on the central display to show the static imbalance by pressing the button , or the eccentricity value (of first harmonic) by pressing the button  (option).

### ► 5.4.1 - IC CORRECTION METHOD

This correction method allows considerably reducing the weight to be applied, yet maintaining excellent balancing quality. The correction plane unbalances are considered within tolerance when both the STATIC and the DYNAMIC TORQUE unbalances are lower than the tolerance set.

To activate press . Enabling the IC correction method is highlighted by a LED which comes ON in the corresponding panel.

## ► 5.5 - RECALCULATION OF THE UNBALANCE

Press  after new setting of the dimensions.

## ► 5.6 - EXACT POSITIONING OF THE ADHESIVE WEIGHT BY MEANS OF THE GAUGE WITH CLIPS

- Press  if using the correction method with weights on the inside of the rim

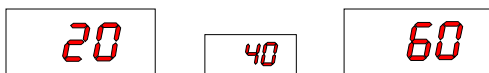

8

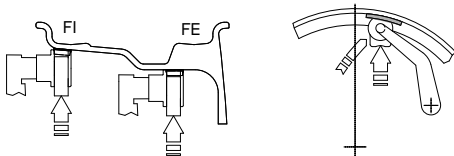

- Fit the correction weight in the specific gauge seat with the adhesive part facing upwards
- Bring the wheel into correct angular position for the plane to be corrected
- If the wheel clamp option is enabled (see **OPERATION FUNCTIONS MENU**), the wheel is automatically clamped in the correction position.
- Pull out the gauge up to the distance set (see **WHEEL DIMENSIONS PRESETTING** b/c)
- If the buzzer is enabled (see **OPERATION FUNCTIONS MENU**), the attainment of the weight application distance is accompanied by a beep.
- If gauge locking is enabled (see **OPERATION FUNCTIONS MENU**), the gauge is automatically locked when the weight application distance is reached. To release the gauge, lower it to below 10" diameter
- Using the special weight pusher, rotate the gauge until the correction weight adheres to the rim.
- the fact that the weight application position is no longer vertical (Fig. 8) is automatically compensated.

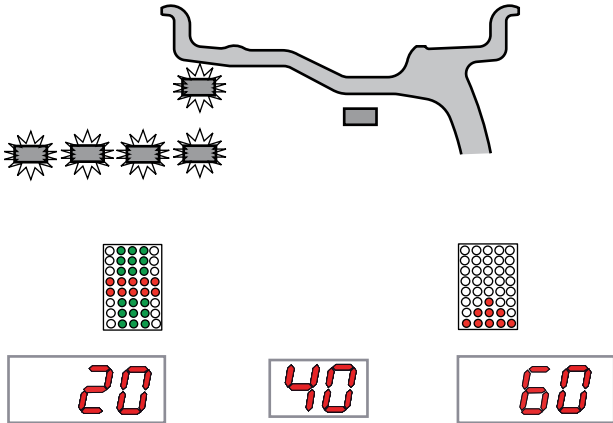

NOTE: The approach of the weights to the correction positions is indicated by the LEDs number 19

► Inside



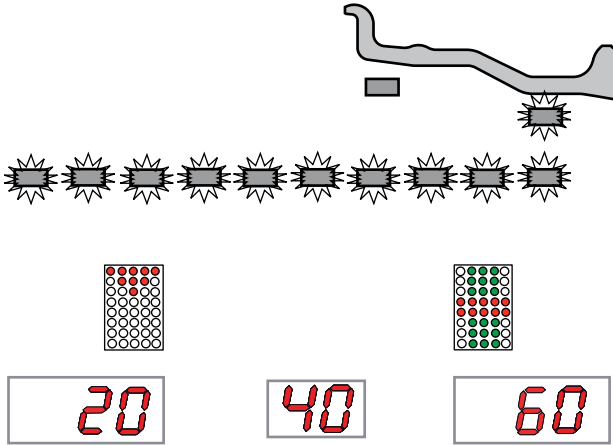





► Outside

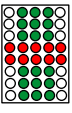
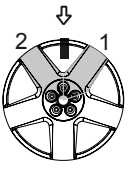
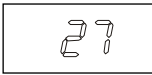
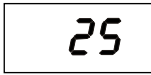
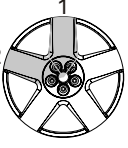
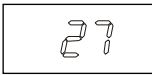

To cancel the function, press the  button again or close the guard and press the  button to start a new spin.

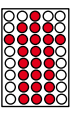
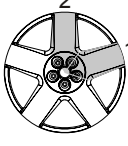
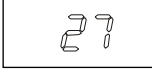
## ► 5.7 - SPLIT FUNCTION (UNBALANCE SPREAD)

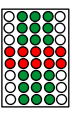
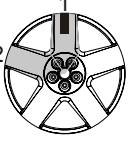
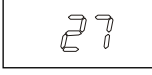
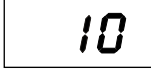
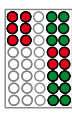
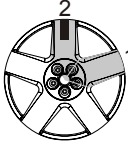
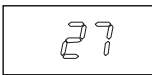
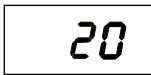
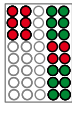
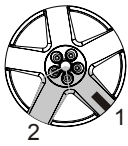
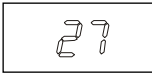
The SPLIT function is used to position the adhesive weights behind the wheel spokes so that they are not visible. This function should be used in ALU mode where the adhesive weight is applied on the outside. Input the wheel dimensions and do a spin.

|   |   |   |   |   |
|---|---|---|---|---|
|    |    |    |    | Turn the wheel to the outside unbalance correction position as indicated by the machine   |
|   |    |    |    | Position one spoke at 12 o'clock (e.g. 1) and press    |
|    |    |    |    | Following the rotation direction indicated on the display, position spoke 2 at 12 o'clock and press  |
|    |    |    |    | Position the wheel as indicated by the LEDs. The unbalance is indicated on the right-hand display   |
|  |  |  |  | Repeat the operation for the other spoke  |
|  |  |  |  | If the OPPOSITE POSITION function is enabled (see <b>OPPOSITE POSITION</b> ), the correction position at the bottom (6 o'clock) is indicated with the following symbol:                 |

To return to normal unbalance display, press any button.

**NOTE:** The distance between the spokes must be at least 18° and at most 120° (if not, the errors 24,25 or 26 appear). Spokes with irregular or inconstant angles can be compensated.

## ► 5.8 - UNBALANCE OPTIMIZATION

- This function serves to reduce the amount of weight to be added in order to balance the wheel
- It is suitable for static unbalance exceeding 30g.
- It improves the residual eccentricity of the tyre.

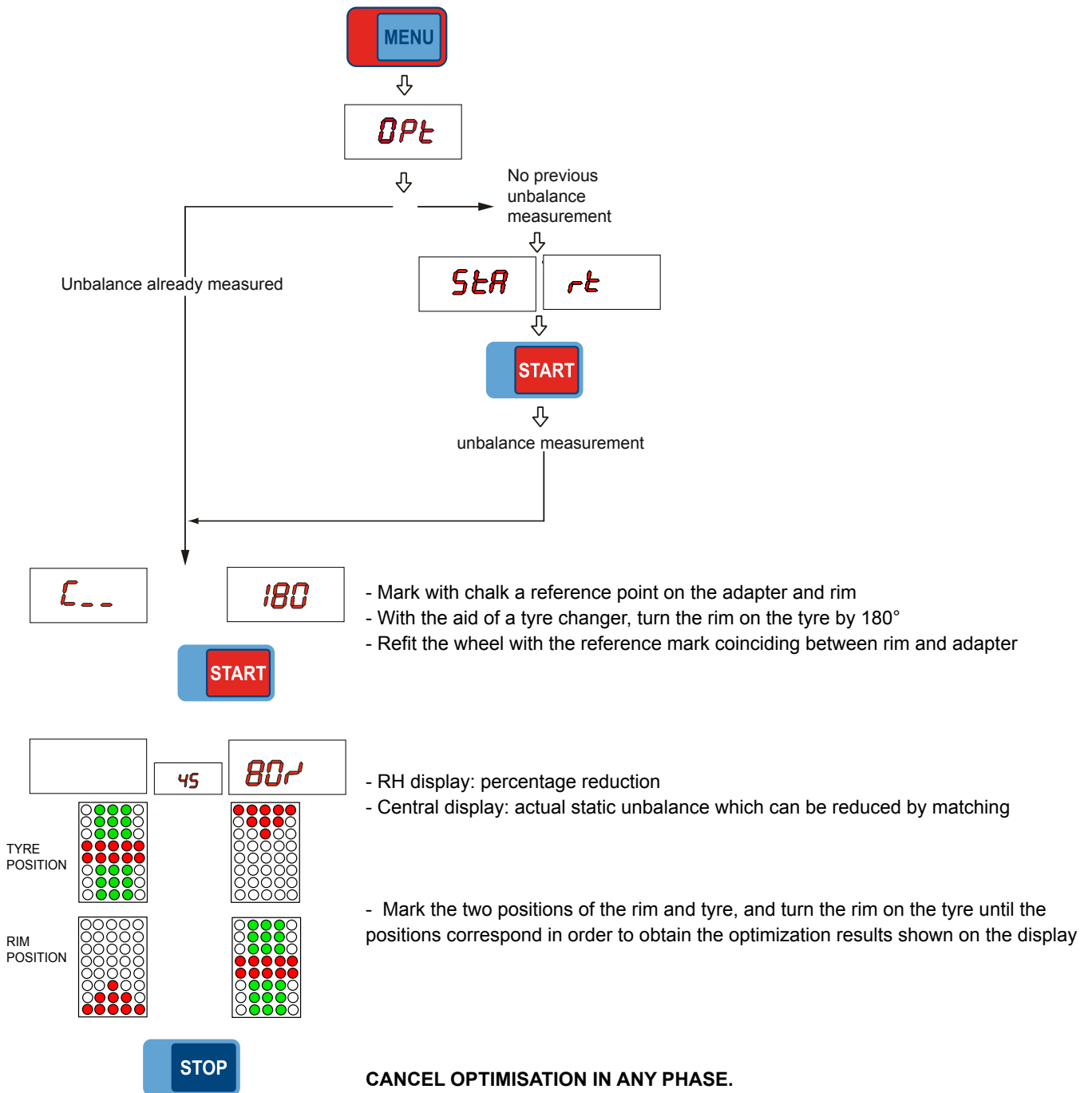

► **5.9 - AUTOMATIC MINIMIZATION OF STATIC UNBALANCE**

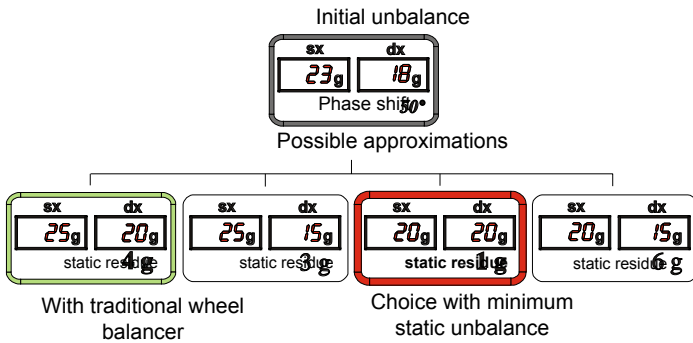

This program is designed to improve the quality of balancing without any mental effort or loss of time by the operator. In fact by using the normal commercially available weights, with pitch of 5 in every 5 g, and by applying the two counterweights which a conventional wheel balancer rounds to the nearest value, there could be a residual static unbalance of up to 4 g. The damage of such approximation is emphasized by the fact that static unbalance is cause of most of disturbances on the vehicle. This new function, resident in the machine, automatically indicates the optimum entity of the weights to be applied by approximating them in an “intelligent” way according to their position in order to minimize residual static unbalance.

► **5.10 - ECCENTRICITY MEASUREMENT**

The much enlarged figures show the outer tyre surface and axis of wheel rotation.

**Fig. A** - shows measurement of the total Peak-to-Peak eccentricity defined as maximum radial deviation of the tyre surface.

**Fig. B** - shows measurement of the eccentricity of the 1st harmonic, i.e. the eccentricity of that circle which “recopies” the tyre shape, by averaging the local deviations of the tyre from the round shape.

Obviously the P.P. measurement is normally greater than that of the 1st harmonic. Tyre manufacturers normally supply two different tolerances for the two eccentricities.

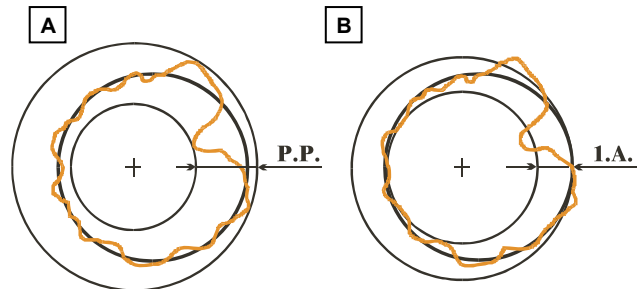

The radial eccentricity measurements is automatically carried out after the unbalance measurement without having to go into particular procedures. Remember to position the sonar sensor in front of the surface to be

measured before pressing the **START** button.

At the end of the cycle, it is possible to show the eccentricity value (first harmonic) detected on the central display, by pressing button **ECC.**. By holding it pressed and turning the wheel, it is also possible to identify the eccentricity phase. When the button is released, the imbalance phases are indicated again.

**N.B.:** *The eccentricity measurement can be enabled/disabled by a specific SETUP function (see OPERATION FUNCTIONS MENU).*

## 6 - SET UP

### ▶ 6.1 - AUTO-DIAGNOSTICS

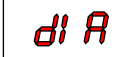
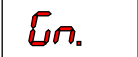
  performs tests useful for maintenance staff.

### ▶ 6.2 - SELF-CALIBRATION

For machine self-calibration proceed as follows:

- Fit a wheel with steel rim on the shaft. Example: 6" x 15" ( $\pm 1$ "), best with less than 20 g unbalance.
- Preset the exact dimensions of the wheel mounted.

**CAUTION!!** Presetting of incorrect dimensions would mean that the machine is not correctly calibrated, therefore all subsequent measurements will be incorrect until a new self-calibration is performed with the correct dimensions!!

 



- Perform a spin under normal conditions.



- Add a 60 g. sample weight (2.00 oz) on the outside in any position.



- Shift the sample weight from the outside to the inside keeping the same position.



- Rotate the wheel so to have the sample weight at the 12 o'clock position.



END OF SELF-CALIBRATION



CANCEL SELF-CALIBRATION IN ANY PHASE.

► **6.3 - MANUAL DIMENSION PRESETTING (Use only in particular cases or for test)**

► **6.3.1 - STEEL WHEEL RIMS (use for setting dimensions in AUTOCALIBRATION)**



9

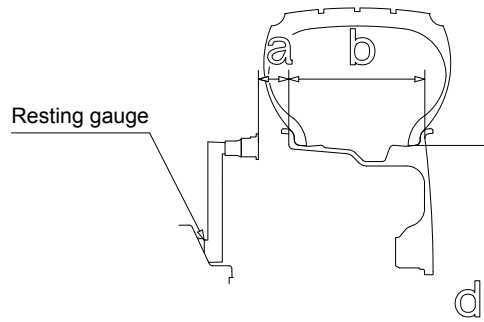

- Setting:



Select by pressing one of the two buttons:

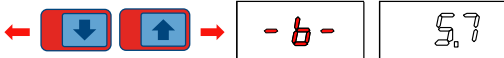

- Set the nominal width, normally indicated on the rim, or measure the width "b" using the caliper gauge supplied (see fig. 9). Press  for more than 2 seconds

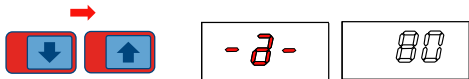

- Set the distance "a" between the inside of the wheel and the machine. Press 

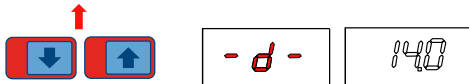

- Set the nominal diameter "d" indicated on the tyre. Press 

N.B.: This setting is also valid for the correction modes indicated at "STATIC & COMBINED MODES".

► **6.3.2 - ALUS RIMS**



10

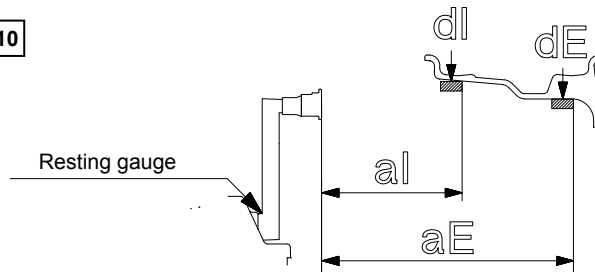

- Setting:



Press one of the two buttons for more than 2 seconds

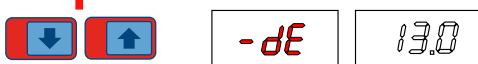
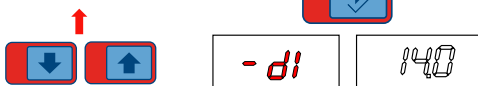
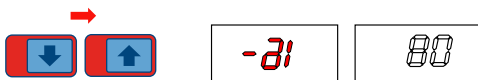

Note: not setting dE as it is automatic,  $dE = dI - 1"$ .

► 6.3.2.1 - ALUS VARIANT WITH INSIDE CLAMP WEIGHT

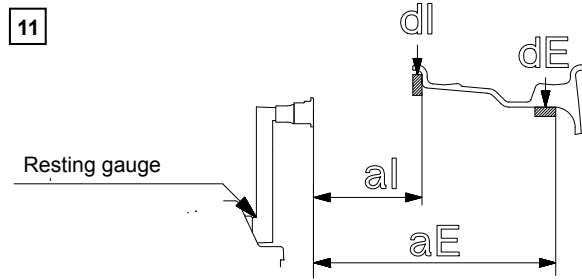

- Setting:

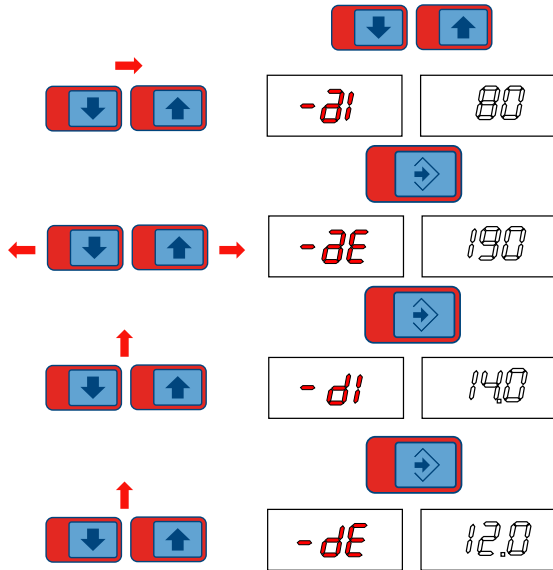

Press one of the two buttons for more than 2 seconds

Note: not setting  $dE$  as it is automatic,  $dE = dI - 2$ .

► 6.4 - GUARD OPENING DURING SPIN

Selecting "ON" the option to open the guard (when the motor is off) during the spin is enabled. If the guard is opened when the motor is on, error 5 (guard open) is displayed. Selecting "OFF", error 5 (guard open) will always be signalled when the guard is opened.

► **6.5 - WHEEL LOCKING**

Enables/disables wheel locking in the correction position through the  button.

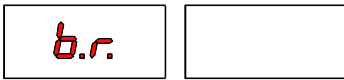

Select ON to enable/OFF to disable the wheel locking

**CONFIRM**



► **6.6 - GAUGE LOCKING**

Enable/disenable the distance gauge locking in the adhesive weight application position.

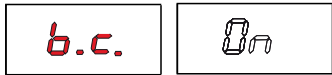

Select ON to enable/OFF to disable the gauge locking

**CONFIRM**



► **6.7 - SPIN TYPE**

You can select STANDARD or FAST. The new developed FAST method allows obtaining stable unbalance values with a shorter cycle time than standard. In FAST mode the measuring accuracy is only insignificantly less.

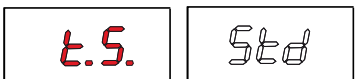
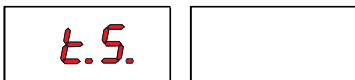

Changes between STANDARD or FAST spin



**CONFIRM**

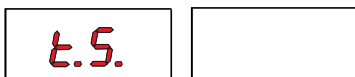

## 6.7 - AUTOMATIC GAUGES CALIBRATION

### ► 6.7.1 - RIM DISTANCE GAUGE

CAL. -0-



r.P.

- Leave the distance gauge in rest position and press



f.P.

- Bring the gauge in contact with the flange surface and press



000 000

#### CORRECT CALIBRATION

- Return the gauge to rest position.
- The wheel balancer is ready for operation.

12

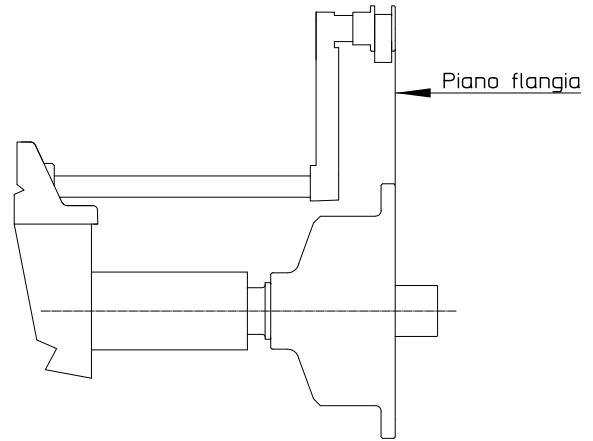
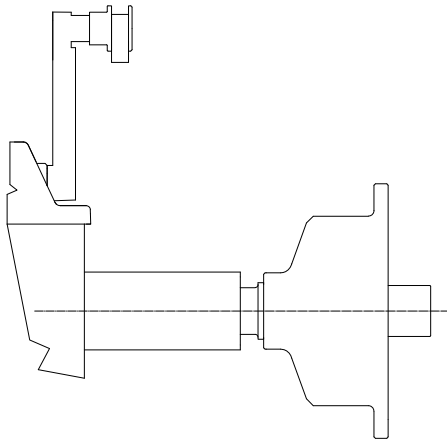

**N.B.:** In the event of errors or faulty operation, the writing “**r.P.**” appears on the display : shift the gauge to the rest position and repeat the calibration operation exactly as described above. If the error persists, contact the Technical Service Department. In the event of incorrect input in the rim distance gauge

calibration function, press

**STOP**

to cancel it.

► 6.7.2 - DIAMETER GAUGE



- Place the round part of the gauge terminal on the flange as shown in the figure and press 



- The number  $353 \pm 3^\circ$  appears on the left display .

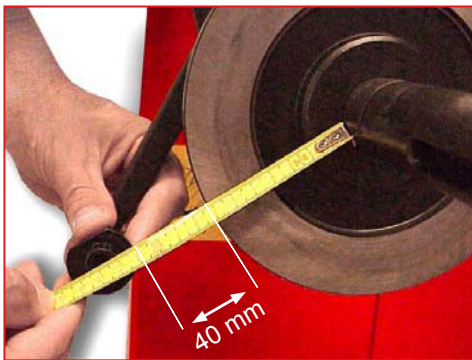

- Turn the gauge downward position the round part of the gauge terminal at 40 mm (radial distance) from the flange as indicated in the figure; alternatively use one of the cones provided as shown in the images

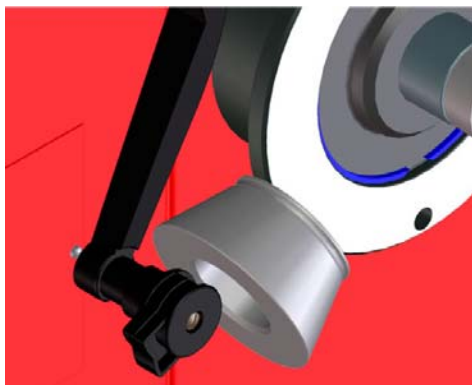

- The number  $256 \pm 3^\circ$  should appear on the left display.

- If not, press the  button holding the gauge still at 40 mm: the number 256 appears on the left display.

- Return the gauge to rest position.

In the event of incorrectly accessing the diameter gauge calibration function, press  to cancel it.

► 6.7.3 - WIDTH SONAR



CAL. -b-



DIS. 515



CAL. -b-

Set with   the distance in mm between the Sonar sensor (0 sonar) and the end of the distance gauge (at rest).

Calibro a riposo

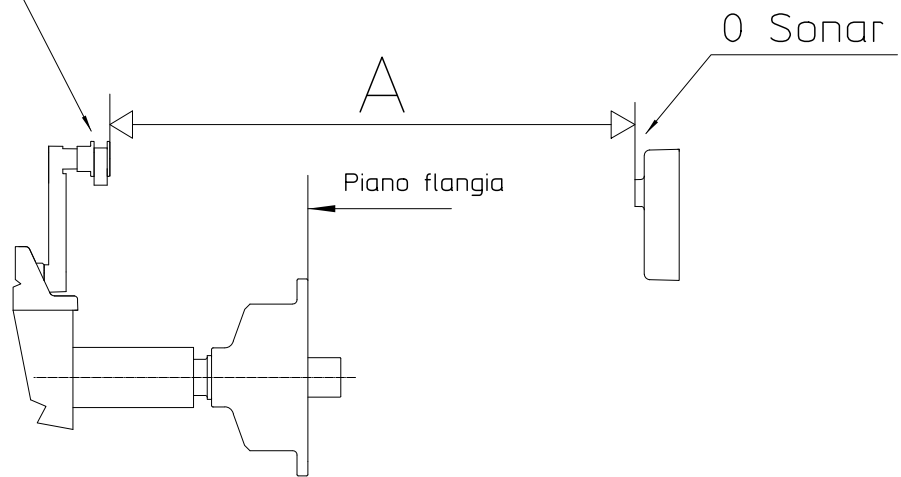

A = Distance: Gauge at rest to 0 sonar

- In the event of incorrect input in the width gauge calibration function, press  to cancel it.

## 7 - ERRORS

During machine operation, various causes of faulty operation could occur. If detected by the microprocessor, they appear on the display as follows:

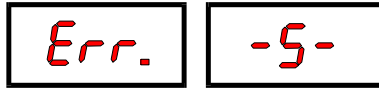

| ERRORS CAUSES   |   | CONTROLS  |
|---|---|---|
| Black   | The wheel balancer does not turn on.  | <ol style="list-style-type: none"> <li>1. Check proper connection to the mains.</li> <li>2. Check and if necessary replace the fuses on the power board.</li> <li>3. Replace the computer board.</li> </ol>   |
| Err. 1  | No rotation signal.   | <ol style="list-style-type: none"> <li>1. Check belt tautness.</li> <li>2. Check functioning of the phase encoder and, in particular, the reset signal.</li> <li>3. Replace the phase encoder.</li> <li>4. Replace the computer board.</li> </ol>   |
| Err. 2  | Too low speed during measurement. During the unbalance measurement revolutions, the wheel speed has fallen to below 42 rpm. | <ol style="list-style-type: none"> <li>1. Check that a vehicle wheel has been mounted on the wheel balancer.</li> <li>2. Check belt tautness.</li> <li>3. Check functioning of the phase encoder and, in particular, the reset signal.</li> <li>4. Replace the computer board.</li> </ol>   |
| Err. 3  | Too high unbalance.   | <ol style="list-style-type: none"> <li>1. Check the wheel dimension setting.</li> <li>2. Check the sensor connections.</li> <li>3. Run the machine calibration function.</li> <li>4. Mount a wheel with a more or less known unbalance (less than 100 grams) and check the machine response.</li> <li>5. Replace the computer board.</li> </ol>       |
| Err. 4  | Rotation in opposite direction. After pressing [START], the wheel starts turning in the opposite direction (anticlockwise). | <ol style="list-style-type: none"> <li>1. Verify the connection of the UP/DOWN - RESET signals on the phase encoder.</li> </ol>   |
| Err. 5  | Guard open<br>The [START] pushbutton was pressed without first closing the guard.   | <ol style="list-style-type: none"> <li>1. Reset the error.</li> <li>2. Close the guard.</li> <li>3. Verify the function of the protection switch.</li> <li>4. Press the [START] button.</li> </ol>  |
| Err. 7 /<br>Err. 8 /<br>Err. 9                                  | NOVRAM parameter read error   | <ol style="list-style-type: none"> <li>1. Repeat machine calibration</li> <li>2. Shut down the machine.</li> <li>3. Wait for at least ~ 1 min.</li> <li>4. Restart the machine and check proper functioning.</li> <li>5. Replace the computer board.</li> </ol>   |
| Err. 11   | Too high speed error.<br>The average spinning speed is more than 240 rpm.   | <ol style="list-style-type: none"> <li>1. Check if there is any damage or dirt on the encoder disc.</li> <li>2. Check functioning of the phase encoder and, in particular, the reset signal.</li> <li>3. Replace the computer board.</li> </ol>   |
| Err.14/<br>Err.15/<br>Err.16/<br>Err.17/<br>Err. 18/<br>Err. 19 | Unbalance measurement error.  | <ol style="list-style-type: none"> <li>1. Check functioning of the phase encoder.</li> <li>2. Check the sensor connections.</li> <li>3. Check the machine earthing connection.</li> <li>4. Mount a wheel with a more or less known unbalance (less than 100 grams) and check the machine response.</li> <li>5. Replace the computer board.</li> </ol> |
| Err.21  | Motor on for more than 15 seconds.  | <ol style="list-style-type: none"> <li>1. Check functioning of the phase encoder.</li> <li>2. Check the connections on the power board.</li> <li>3. Replace the computer board.</li> </ol>  |
| Err.22  | Maximum number of spins possible for the unbalance measurement has been exceeded.   | <ol style="list-style-type: none"> <li>1. Check that a vehicle wheel has been mounted on the wheel balancer.</li> <li>2. Check belt tautness.</li> <li>3. Check functioning of the phase encoder and, in particular, the reset signal.</li> <li>4. Replace the computer board.</li> </ol>   |
| Err. 24   | Distance between the spokes smaller than 18 degrees.  | <ol style="list-style-type: none"> <li>1. The minimum distance between the spokes where to split the unbalance must be more than 18 degrees</li> <li>2. Repeat the SPLIT function increasing the distance between the spokes.</li> </ol>  |

|         |  |  |
|---------|--|--|
| Err. 25 | Distance between the spokes greater than 120 degree  | <ol style="list-style-type: none"> <li>1. The minimum distance between the spokes where to split the unbalance must be less than 120 degrees</li> <li>2. Repeat the SPLIT function increasing the distance between the spokes.</li> </ol>  |
| Err. 26 | First spoke too far from unbalance position  | <ol style="list-style-type: none"> <li>1. The minimum distance between the unbalance position and the spoke must be less than 120 degrees.</li> <li>2. Repeat the split function reducing the distance between the spokes.</li> </ol>  |
| Err.55  | Sonar readout error.<br>Sonar values are insufficient for correct measurement of eccentricity. | <ol style="list-style-type: none"> <li>1. Position the eccentricity measurement sonar correctly before performing the measurement.</li> <li>2. Make sure that the wheel does not halt before completing at least 4/5 revolutions after the first braking impulse.</li> <li>3. Verify belt tautness.</li> <li>4. Mount a wheel of medium dimensions (14"x5 3/4") and perform an eccentricity measurement . If in these conditions error 55 no longer occurs, this means that the wheel inertia causing the problem is such as to half the wheel before having acquired the minimum number of values necessary for reliable eccentricity measurement.</li> </ol> |
| Err.56  | Lateral Sonar readout error.<br>Lateral Sonar value readout impossible.                        | <ol style="list-style-type: none"> <li>1. Position the eccentricity measurement lateral sonar correctly before performing the measurement.</li> <li>2. Check eccentricity lateral sonar connections.</li> <li>3. Check the power supplies on the power board.</li> <li>4. Replace the eccentricity lateral sonar.</li> <li>5. Make sure that the wheel does not stop before completing at least 4/5 revolutions after the first braking impulse.</li> <li>6. Verify belt tautness.</li> <li>7. Replace the computer board.</li> </ol>  |

### ► **7.1 - INCONSISTENT UNBALANCE READINGS**

Sometimes after balancing a wheel and removing it from the balancing machine, it is found that, mounting it on the machine again, the wheel is not balanced.

This does not depend on incorrect indication of the machine, but only on faulty mounting of the wheel on the adapter, i.e. in the two mountings the wheel has assumed a different position with respect to the balancing machine shaft centre line. If the wheel has been mounted on the adapter with screws, it could be possible that the screws have not been correctly tightened, i.e. crosswise one by one, or else (as often occurs) holes have been drilled on the wheel with too wide tolerances. Small errors, up to 10 grams (0.4 oz) are to be considered normal in wheels locked by a cone; the error is normally greater for wheels fastened with screws.

If, after balancing, the wheel is found to be still out-of-balance when refitted on the vehicle, this could be due to unbalance of the car brake drum or very often due to the holes for the screws on the rim and drum sometimes drilled with too wide tolerances.

In such case a readjustment could be advisable using the balancing machine with the wheel mounted on the car.

## **8 - ROUTINE MAINTENANCE**

Switch off the machine from the mains before carrying out any operation.

### ► **8.1 - TO REPLACE THE FUSES**

Remove the weight holder shelf to gain access to the power supply board where the fuses are located (see Exploded Drawings). If fuses require replacement, use ones of the same current rating.

If the fault persists, contact the Technical Service Department.

***NONE OF THE OTHER MACHINE PARTS REQUIRE MAINTENANCE***